

Oconee County Building Codes

415 South Pine Street Walhalla, South Carolina 29691

Phone: 864-718-1005

Fax: 864-638-4168

www.oconeesc.com



Residential Inspection Checklist “Am I ready for inspection?”

Attached is the residential inspection checklist. It is intended as a tool for inspectors, builders, and contractors, in reference to the 2006 *International Residential Code*. (IRC) and the 2006 *International Energy Conservation Code* (IECC). This can be purchased through bookstores or at the International Code Council. www.iccsafe.org It is not all-inclusive or to replace the code, but to be used as a guide for normal inspection procedure. It will be updated as code cycles change and new building technologies come out. It is the responsibility of the builder and subcontractor to ensure the homes they construct are in full compliance with all applicable codes, laws, and ordinances. Oconee County Building Codes is partnered with these groups to ensure the health safety and welfare of our community. This checklist serves as first and final notice of Oconee County Building Codes intention to enforce the codes. We appreciate your cooperation with these procedures. We have also attached state modifications and a visual interpretation of the Residential code in reference to stairways.

Typical Inspection Procedure

Under normal conditions the following sequence of inspections will be utilized. Alternate methods of construction may require additional inspections. It is the responsibility of the builder, or his authorized agent, to contact the department to request an inspection. Please have your permit number when calling. Every effort will be made to do the inspection the next working day. Due to workload demand this is not always possible, so please schedule accordingly. Inspections should be ready when calling or a reinspection fee will be assessed. It is the responsibility of the builder to provide access and means for inspection. Work shall not be done beyond the point indicated in each successive inspection without approval of the building inspector or official. No building shall be used or occupied until final inspection is made and a certificate of occupancy is provided. (IRC.109, 110)

- 1) **Footing Inspection:** When the footing/foundation is complete. Prior to the placement of concrete. With permission a qualified SC engineer may do third party inspection. (See Third Party Form)
- 2) **Plumbing under Slab Inspection:** Plumbing test is on with fittings exposed. This may be done with foundation inspection.
- 3) **Foundation Inspection:** Prior to backfill, waterproofing and french drains in place, anchorage installed.
- 4) **Rough-In Inspection:** Prior to insulation or sheetrock. The house is dried-in, framing, HVAC, plumbing, and electrical roughed-in at this time. Permanent power and gas tags placed at this time.
- 5) **Final Inspection:** Prior to occupancy or use, building is substantially complete with all code issues addressed. A written Certificate of Occupancy will be issued upon request within 48 hours.

Inspections may be combined at the builder's discretion. For example, detached garages usually involve a combined footing and slab. (monoslab) Modular homes, log homes, or alternate methods will follow similar inspection procedures. Additional or Courtesy inspections may be required as design dictates. Any alternate method will require prior approval from plan review. (IRC 104, 106) For example, a stick built home, otherwise built to the IRC, can integrate pre-engineered building components without having to engineer the entire structure. Please feel free to contact the department with questions.

Updated 7/1/09

Footing Inspection

- 1) Work must be completed. Due to the workload we are not able to give a specific time for the inspection beyond the date of the inspection. Every effort will be made to do inspections in the morning beginning at 8:30. If time or weather is a factor, Third Party Inspection Letters are permitted with professional engineering. Please see that form for details.
- 2) The jobsite must be accessible. In cooperation with DHEC, State and County road departments we ask that erosion control, silt fences, and gravel access drives be used and maintained.
- 3) Permit must be posted until completion of project. Please keep it dry, accessible, and easily seen. *105.7*
- 4) 911 address # must be posted with 3" or larger numbers. *321.1*
- 5) "Port-a-john" toilet facilities must be provided for construction workers. *IPC 311*
- 6) Building setbacks less than 5 feet from lot lines or another building require firewall construction. *302.1*
- 7) No mud or water is allowed in the footing. The builder responsible for the job is required to call and cancel the inspection if the inspection cannot be performed due to inclement weather. *109.3*
- 8) Remove all vegetation, topsoil, and organic material from the area inside the foundation. *408.5*
- 9) All exterior footings shall be placed at least 12 inches below undisturbed ground surface. Formed footings are only allowed below the undisturbed grade plane. (i.e. basements) *403.1.4*
- 10) Footings must be level, "hog outs" are not allowed. Stepped footing bulkheads must be properly in place at time of inspection to maintain a continuous level footing. Remove all wood prior to wall construction. "Cold" pours are not allowed without a design professional. *IRC 403.1.5*
- 11) Rebar is not required per code, but must be installed correctly if used. Wooden grade stakes, red brick chairs, inadequate concrete coverage, and improper slice lap ties are not allowed. Rebar is a made grounding electrode and a minimum No. 4 AWG bare copper conductor must be bonded and extended to the electrical system. *IRC 3508*
- 12) Soils tests are encouraged and may be required if soil is questionable or on engineered fill. The maximum presumed load-bearing value for clay is 1500 psf. *Table 401.4.1* Footings should be sized to accommodate all loads. Depth is generally one-half the minimum width, but projections, cannot exceed the depth. Spread footings may use the following chart as a minimum footing width: *2006 IRC 403.1*

Minimum Width of Concrete Footings (inches)

Load Bearing Value of Soil	1500 PSF
Light-frame construction (vinyl)	
1-story	12
2-story	15
3-story	23
4 inch brick veneer or 8 inch hollow masonry	
1-story	12
2-story	21
3-story	32
8 inch masonry (basements) solid	
1-story	16
2-story	29
3-story	42

Under-Slab Inspection

- 1) Slab inspections are required for monolithic slabs with integral footings and/or whenever any utility (plumbing, electrical, or mechanical duct or condensate) is located underneath a slab. Under normal circumstances, trenches outside the footprint of the house (i.e. septic, waterlines, electrical, etc.) and nonstructural building slabs for single family dwellings are not required inspections by Building Codes.
- 2) Plumbing must be tested by a water or air pressure test. Drains (DWV) must have a minimum 10-foot head of water from the highest fitting connection, or 5-psi air pressure test. Straight runs may be covered but fittings must remain exposed. Water tests are not recommended in rainy weather. Supply water tests are recommended but not required until rough in inspection. *2503*
- 3) Properly size, fit, and slope drains. *3005*
- 4) Use proper primer and solvent. Purple primer is the standard for PVC fittings. Do not mix ABS and PVC. *3003.2*
- 5) Provide drain cleanouts prior to entering slab. *3005.2*
- 6) Sleeve piping (DWV, water, gas etc.) through foundation walls and through concrete. Piping must be properly protected from impact and corrosion. *2603*
- 7) Bearing points for columns and bearing walls should be formed and clearly defined at inspection. *501.2*

Oconee County generally no longer requires a slab inspection on single family garages or porches but will spot check for the following items:

- 8) A 4-inch thick base course of gravel or stone placed. *504.2.1*
- 9) Compacted fill over 24" deep requires a soil compaction report by a qualified engineer. *506.2.1*
- 10) A vapor barrier is required under all slabs within the building envelope over the gravel base. 6-mil. poly overlapped and taped extending up the wall 6 inches. *506.2.3 IECC 402.2.8*
- 11) Slabs must be a minimum 3.5 inches thick and capable of carrying all loads. *506.1*
- 12) Garage floors must be sloped to facilitate the movement of liquids. *309.3* See DHEC for floor drain requirements. Elevated garage floors must be engineered to support a 2000 lb. load over a 20" square area. *301.4*
- 13) Slabs poured prior to inspection or without vapor barrier may be subject to removal and replacement. *114.1*
- 14) According to the protection chosen, termite chemical soil treatment maybe needed prior to pour. Provide letter at final inspection. *320*
- 15) **Radon Gas has been found in the past in Oconee County.** There is **moderate potential** for radon according to the *EPA* and *USGS*. Soil gas stacks are not required but must be labeled if used to avoid confusion with DWV.

Foundation Inspection

- 1) ½" Anchor bolts are required within 12 inches of each corner and the end of each sill plate and every 6 feet. Anchor straps are allowed per manufacturers' installation instructions, usually 3' on center. *403.1.6*
- 2) All wood that rest on concrete or masonry or less than 8" from grade must be pressure treated. *319.1*
- 3) Wall thickness is based upon walls supported. Minimum thickness for single story masonry foundations is 6", two story is 8". Pier and Curtain is allowed on light frame construction only up to 4 feet and as per *404.1.5*. Pier and veneer is not prescribed by code and would require engineering. *606.8*
- 4) Maximum unbalanced fill for 4" pier and curtain walls is 1 foot, hollow 8" CMU is 4 feet, solid grouted 12" CMU is 6 feet, 12" plain concrete wall is 8 feet. Any foundation wall that exceeds this would require engineering. *Table 404.1.1(1)*
- 5) Backfill should not be placed against the wall until the wall has sufficient strength, anchorage, and bracing. *404.1.7*
- 6) Waterproofing, damp proofing, and foundation drainage ("french drains") should be inspected at this time. Foundation drainage shall positively slope to daylight as site conditions warrant. Exterior waterproofing and drainage system are required on all basements, habitable spaces, and useable spaces and when the inside grade of the crawl space is lower than the finished outside grade. *405, 406, 408.6*
- 7) Masonry walls shall be solid units or grouted at a change in thickness. *606.2.3*
- 8) An 18" by 24" crawl space access shall be maintained. *408.4 and SC amendment*
- 9) Crawl spaces shall be vented with a 1/1500 ratio with an approved 6 mil. Vapor barrier installed. Notice an 8" by 16" foundation vent does not equal one square foot of ventilation. *408.2*
- 10) 8" CMU piers cannot exceed 80" height. Piers over 32" high must be filled solid and capped. *606.6*
- 11) Masonry walls shall be laterally supported. Usually with a 1/20 ratio. *606.9*
- 12) Flashing and weep holes must be installed correctly. Drilling weep holes is not an acceptable practice. This may be inspected at later inspections. *703.7.5, 703.7.6, 703.8*
- 13) Minimum net area of ventilation openings shall not be less than 1 square foot for each 150 square foot of under floor space. The total area of ventilation openings may be reduced to 1/1500 of the under-floor area where the ground surface is treated with an approved vapor retardant material and the required openings are placed so as to provide cross-ventilation of the space. *408.2 and SC amendment.*
- 14) Unvented crawl spaces are addressed in section 408.3, 2006 IRC.

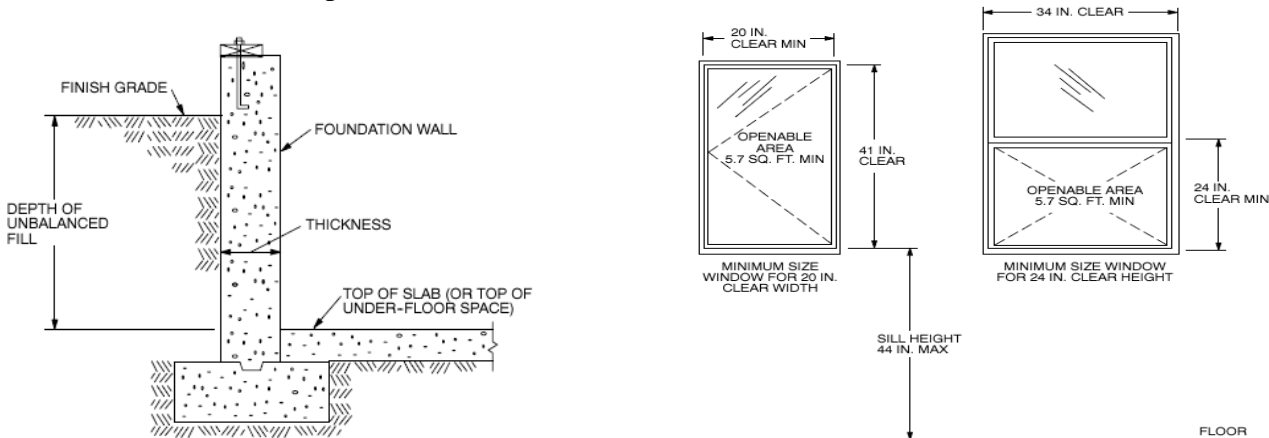

Rough-in Inspection

1. All sub-trade rough-ins (plumbing, gas, mechanical, and electrical) must be ready.
2. All masonry and rough framing completed. The structure must be dried-in, doors and windows installed, masonry fireplaces and roof flashing and shingles completed. Do not insulate except concealed walls such as behind showers and cantilevered floors. Do not stack sheetrock along walls. If a door or window is backordered, please weatherproof the opening with poly. *701.2*
3. Every dwelling must have one 3/0 by 6/8 side hinged exit door. Every sleeping room must have an emergency egress window or exit door. The window sash must clear open at least 20" wide, 24" tall, be within 44" of the floor, and have an overall opening size of **5.7 net clear feet**. (821") A sleeping room is any room with a clothes closet including basements and bonus rooms. *310, 311.4.2 see picture page 4*
4. Every stair must be a minimum dimension of 3 feet in the direction of travel. The landing width shall not be less than the stairs served. A landing shall be provided at top and bottom of stairway. Stair headroom, measured from the slope of the stairs, must be over 6' 8". *311.5 See picture page 10*
5. Glazing of windows in hazardous locations must be **tempered**. (i.e. doors, next to doors, over tubs, large picture windows, etc.) Glazing in doors and enclosures for hot tubs, whirlpools, saunas, steam rooms, bathtubs and showers shall be tempered where the bottom exposed edge of the glazing is less than 60 inches measured vertically above any standing or walking surface. *308.4 and SC amendment.*
6. All structural members, their size, spans, and method of attachment are to be in accordance with the code. Any alternate material not prescribed in the code must be approved. *301.1.3*
7. Cuts, notches, and holes bored in laminated veneer lumber, glue-laminated members, or I-joist are not permitted beyond the manufacturers installation guide. Truss members shall not be altered in any way without the approval of a design professional. Truss design drawings shall be provided. Use "hurricane clips" and tie downs as specified per manufacturer. (Any rafter to plate connection with more than 175 lbs of uplift) *502.8.2, 502.11, 802.10.1*
8. All load bearing lumber must be grade stamped. Structural logs shall also be grade stamped *602.1*
9. Any framing member that has been cut or notched beyond allowances must be reinforced. *602.6*
10. Wall bracing according to Design category C. *602.10.3, 606.5*
11. A 22" by 30" minimum attic access must be provided. A larger opening may be required when equipment is located in the attic. Shall have a vertical clearance of 30 inches. *807.1*
12. Fire blocking shall be in place. Use ASTM E136 caulk and other approved materials to seal each vertical and horizontal penetration at 10'. (enclosed chases, floor/ceiling penetrations, soffits, stairs, tubs, etc.) Draftstop every 1000 square foot of concealed space. *502.12, 602.8*
13. All exterior siding material requires a weather resistant membrane (30# felt or house wrap, "Tyvek") between masonry veneer, EIFS, vinyl or stucco. Do not install an interior (conditioned side) vapor barrier this will lead to moisture problems in the stud cavity.
14. Foam plastic may be used if separated from the interior with sheetrock. *703, 318*
15. Flash porches, window and door sills, and nailing flanges per manufacturer, Wall sheathing should be at least 6" from grade. *703.8, 319.1*
16. The following header charts may be used instead of the prescribed method. (*1995 CABO, S.C.B.C.C.*)

SIZE OF HEADERS	HEADERS IN BEARING WALLS (FEET)			NON-LOADBEARING
	ROOF	1 STORY (floor)	2 STORY	
DOUBLE 2X4	4	-	-	-
DOUBLE 2X6	6	4	-	-
DOUBLE 2X8	8	6	-	10
DOUBLE 2X10	10	8	6	12
DOUBLE 2X12	12	10	8	16

Alternative to IRC Table R502.5(1)

Number of Jack Studs and Maximum Spans for No. 2 SYP Girders and Headers in Exterior Bearing Walls with 10 psf Ground Snow Load

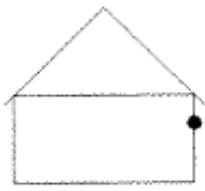
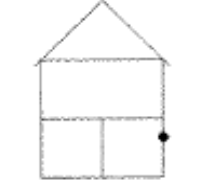
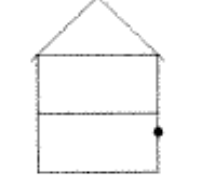
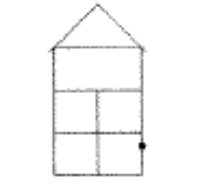
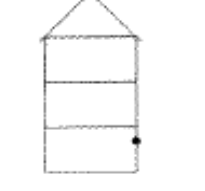
Headers Supporting	Size	Building Width (feet)							
		12		20		28		36	
		Span	NJ	Span	NJ	Span	NJ	Span	NJ
	2-2x4	5-2	1	4-2	1	3-7	1	3-2	1
	2-2x6	7-6	1	6-0	1	5-1	1	4-7	1
	2-2x8	9-8	1	7-8	1	6-7	1	5-10	1
	2-2x10	11-7	1	9-2	1	7-10	1	7-0	1
	2-2x12	13-7	1	10-9	1	9-3	1	8-2	1
	3-2x8	12-8	1	10-2	1	8-8	1	7-8	1
	3-2x10	15-2	1	12-1	1	10-4	1	9-2	2
	3-2x12	17-9	1	14-2	1	12-2	2	10-9	2
	4-2x8	14-8	1	11-8	1	10-0	1	8-10	2
	4-2x10	17-7	1	14-0	1	12-0	2	10-8	2
	4-2x12	20-6	1	16-4	2	14-0	2	12-6	2
		2-2x4	---	---	3-3	1	2-9	1	2-6
2-2x6		---	---	4-9	1	4-1	1	3-7	1
2-2x8		---	---	6-2	1	5-3	1	4-8	1
2-2x10		---	---	7-4	1	6-3	1	5-7	1
2-2x12		---	---	8-7	1	7-4	2	6-6	2
3-2x8		---	---	8-1	1	6-10	1	6-1	2
3-2x10		---	---	9-8	1	8-4	2	7-3	2
3-2x12		---	---	11-3	2	9-8	2	8-7	2
4-2x8		---	---	9-4	1	8-0	2	7-1	2
4-2x10		---	---	11-2	2	9-6	2	8-4	2
4-2x12		---	---	13-1	2	11-2	2	9-10	2
		2-2x4	3-7	1	2-10	1	2-4	1	2-1
	2-2x6	5-2	1	4-1	1	3-6	1	3-1	1
	2-2x8	6-8	1	5-3	1	4-6	1	4-0	1
	2-2x10	8-0	1	6-3	1	5-4	2	4-8	2
	2-2x12	9-4	1	7-4	2	6-3	2	5-7	2
	3-2x8	8-9	1	6-10	1	5-10	2	5-2	2
	3-2x10	10-7	1	8-3	2	7-1	2	6-2	2
	3-2x12	12-4	2	9-8	2	8-3	2	7-3	2
	4-2x8	10-2	1	8-0	2	6-9	2	6-0	2
	4-2x10	12-2	2	9-7	2	8-1	2	7-2	2
	4-2x12	14-3	2	11-2	2	9-6	2	8-4	3
		2-2x4	---	---	2-10	1	2-4	1	2-1
2-2x6		---	---	4-1	1	3-6	1	3-1	1
2-2x8		---	---	5-4	1	4-6	1	4-0	1
2-2x10		---	---	6-3	1	5-4	2	4-8	2
2-2x12		---	---	7-4	2	6-3	2	5-7	2
3-2x8		---	---	6-10	1	5-10	2	5-2	2
3-2x10		---	---	8-3	2	7-1	2	6-2	2
3-2x12		---	---	9-8	2	8-3	2	7-3	2
4-2x8		---	---	8-0	2	6-9	2	6-0	2
4-2x10		---	---	9-7	2	8-1	2	7-2	2
4-2x12		---	---	11-2	2	9-6	2	8-4	3
		2-2x4	2-10	1	2-3	1	2-0	1	1-8
	2-2x6	4-2	1	3-3	1	2-9	1	2-6	1
	2-2x8	5-6	1	4-3	1	3-7	2	3-2	2
	2-2x10	6-6	1	5-1	2	4-3	2	3-9	2
	2-2x12	7-7	1	6-0	2	5-1	2	4-6	2
	3-2x8	7-2	1	5-7	2	4-9	2	4-2	2
	3-2x10	8-7	2	6-8	2	5-8	2	5-0	2
	3-2x12	10-0	2	7-9	2	6-8	2	6-10	3
	4-2x8	8-3	2	6-6	2	5-6	2	4-10	2
	4-2x10	9-10	2	7-8	2	6-7	2	5-9	3
	4-2x12	11-7	2	9-1	2	7-8	3	6-9	3

Building width is measured outside to outside and perpendicular to the ridge. For width between those shown, spans are permitted to be interpolated. Table assumes 1 ft roof overhang, 10 psf DL roof, ceiling and floors, 20 psf LL roof (construction load) and 40 psf LL floors.

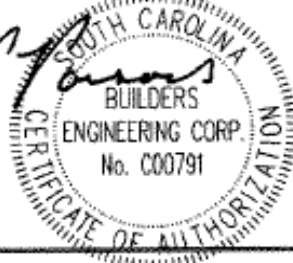

BUILDERS ENGINEERING CORP. Two Hillstone Court Columbia, SC 29212	Generated By: G. Parsons PE Verified By: D. Jones PE
www.BuildersEngineering.com (803) 466-2466	October 23, 2006 Note: Check website for later revision

Plumbing Rough –In

- 1) Plumbing shall be roughed in to all locations.
- 2) Drain systems shall be tested by water with no evidence of leaking. Fill to highest flood level rim. *2503.5.1*
- 3) Water supply system shall be tested and proved water tight under a water pressure test not less than the working pressure of the system (min. 40 psi) or by an air test not less than 50 psi. (100 psi for pex.) *2503.6*
- 4) Radiant floors and ground source heat pumps must be pressure tested at 100 psi. *2101.10*
- 5) Where piping is installed through holes in plates or studs less than 1.5” from the nearest edge of the member, shield plates shall protect the pipe. *2603.2.1*
- 6) Shower valves shall limit water temperature to 120 degrees.. *2708.3*
- 7) Vent terminals min. 6” above roof. Roof boots should be installed. *3103, 2606*
- 8) Vent terminals shall not be within 10 feet horizontally of openings into the building unless it is at least 2 feet higher than the opening. *3103.5*
- 9) PVC pipe is not allowed for any water distribution inside the building. *Table 2904.5*
- 10) *The International Plumbing Code* is a referenced standard and may be used in conjunction with the *IRC*.

Mechanical Rough-In

- 1) Gas pipe shall be run to all locations and pressure tested. Test must be gauged from the location of the meter through the foundation to the approximate location of all appliances. Minimum test is 20 psi and the gauge must be calibrated (100 psi max) to discern any leak. Fort Hill Natural Gas may be contacted at 882-8126. Manifold systems should have flexible connectors in place for tests. All CSST pipe shall be bonded per manufacture specifications. *2417.4*
- 2) Use only approved piping materials. (Copper, CSST, Black steel and wrought iron) Properly size and support gas piping. No unions, couplings, bushings or flared fittings shall be in concealed locations. Protect copper or CSST piping when passing through wood members with shield plates. Protect piping against corrosion when passing through foundation walls and exposed in exterior locations. *2414-2418*
- 3) Fireplaces, vented or un-vented, must be installed. If gas is to be used in such fireplace, the gas line must be run and tested. *2417.1*
- 4) Fuel fired appliances are restricted in sleeping rooms, bathrooms, and storage closets. See manufacturer’s guidelines for exceptions. *2406.2*
- 5) Air returns must be installed. Prohibited in kitchens, bathrooms, garage, and within 10’ of fuel fired appliance. *1602.2*
- 6) Supply boots must be installed and insulated in non-conditioned spaces conducive to condensation. *1601*
- 7) Primary Condensate and HVAC line sets should be installed and firestopped. *602.8*
- 8) All chimneys and vents shall be inspected for proper size and clearances. A mechanical draft venting system shall terminate at least 3 feet above any air inlet located within 10 feet. *2427.6.3*
- 9) Clothes dryer exhaust duct shall be roughed-in. Maximum length not to exceed 35 feet or provide manufactures listing. (*State modification*)
- 10) Exhaust fans or operable windows must be installed in every bathroom and water closet. Fans ducted to outside air. *303.3*
- 11) Building thermal envelope durably sealed to prevent air infiltration. *IECC 402.4.1*
- 12) *The International Mechanical Code* and *The International Fuel Gas Code* are referenced standards and may be used in conjunction with the *IRC*.

Electrical Rough-In

- 1) The panel box needs to have the grounds and neutrals made up. No breakers are required. Service entrance must be run.
- 2) Wiring must be run to all locations.
- 3) Service loads shall be computed in accordance with the code. Services over 400 amps require a design professional. *3502*
- 4) Unless the meter base and service panel are located back-to-back or next adjacent stud cavity, a four wire system with an exterior service disconnect is required. The sub-panel must isolate grounds from neutrals. *National Electric Code (NEC) 230.70a and 230.91a*
- 5) **Panel box** locations must meet clearance (30" wide by 36" deep by 6'6" high) and **cannot be located in a bathroom or clothes closet.** *3305*
- 6) Two secondary ground rods, minimum 6 foot apart are required where a made rebar ground was not installed, or when a single electrode does not have a resistance to ground of less than 25 ohms.
- 7) A four-wire system is required for stoves and dryers. *NEC 400.5 or 250.59b*
- 8) Bond all metal water pipes. *3509.6*
- 9) Receptacle spacing on walls shall be not more than 12' apart, within 6' of any door, and on any wall over 2' in length. *3801.2.1*
- 10) A minimum two 20-amp circuits are required in the kitchen, one in the laundry, one in the bathroom this mandates 12 gauge wire size. *3603*
- 11) Kitchen countertop receptacle spacing is basically 2' on center, with one receptacle required in any island, peninsula or countertop over certain size. *3801.4*
- 12) Wiring shall be protected from abrasion. *3805.1.2*
- 13) Holes closer than 1 ¼" from the edge of the stud or plate shall be protected by nail guards. *3702.3.2*
- 14) Use only UL listed fixtures as they are designed. (ceiling fans, wet and damp locations, recessed can lights) *3903*
- 15) A 125-volt, single-phase, 15 or 20 ampere-rated receptacle outlet shall be installed at an accessible location for the servicing of heating, air conditioning and refrigeration equipment located in attics and crawl spaces. The receptacle shall be located on the same level and within 25 feet (7620 mm) of the heating, air-conditioning and refrigeration equipment. The receptacle outlet shall not be connected to the load side of the HVAC equipment disconnecting means. *SC Amendment*
- 16) Smoke alarm wiring must be installed. One is required inside each sleeping room, outside each sleeping room, and on each floor level. They must be "hardwired", interconnected, and have battery backup. Refer to the manufacturer's installation instructions for specific application but in general, they must be located within 12" of the ceiling or on the ceiling and 3 feet from any source of air movement. (returns, registers, ceiling fans) Non required detectors located in areas prone to false alarms, (attics, garages, kitchens, bathrooms) should be photoelectric or heat detectors. *313*
- 17) Temporary Permanent Power (contingent upon a Certificate of Occupancy at final inspection) will be granted after rough-in inspection is passed.
- 18) *The National Electric Code* is a referenced standard and may be used in conjunction with the *IRC*.

Final Inspection

- 1) Building must be completed and ready for inspection. All life safety issues must be resolved.
Warning: Buildings may not be occupied prior to a final inspection being passed and a Certificate of Occupancy being issued by the Building Official. Please call Building Codes in advance if there is any question regarding this. Building Codes does not inspect cosmetic items, nor do a “punch list”. Questions concerning these items can be found through the Residential Builders Commission.
www.llr.sc.state The Certificate of Occupancy can be requested the following business day after the final has passed. Physical occupancy, (move in furniture, etc.) can occur as soon as the permit holder has obtained a verbal verification from the building inspector. *110.3*
- 2) Prior to scheduling a final inspection a termite protection letter, energy compliance certificate (page 13), and the completed septic or sewer system letter must be presented to Building Codes. FAX # 638-4168
- 3) It is the permit holder’s responsibility to ensure that the permit reflects the structure as built. Structural change orders and additional square footage must be properly permitted and inspected. *106.4*
- 4) Emergency 911 address numbers must be permanently posted on the house. If more than 50 feet from the road they must be posted there as well. Numbers must be 3” or larger. *County Ordinance 2001-06*
- 5) Final grade must slope a minimum of 6” over 10’ fall. Where this cannot be obtained the final grade shall slop away from the foundation at a minimum slope of 5 percent. Gutters with 5’ downspout extensions may be required where site conditions warrant. Impervious surfaces shall have a minimum 2 percent slope. *401.3, 801.3*
- 6) The exterior must be weatherproof and rodent proof.
- 7) The garage shall be separated from the residence and its attic area by not less than ½” sheetrock on the garage side walls and structural support and 5/8” Type X sheetrock on the ceiling. Sheetrock must be butted tight and must be mud and taped one time to US Gypsum association standards. Doors opening from the garage to a sleeping room are not allowed. Doors shall be 1 ¾” solid wood or metal. Fiberglass, Masonite, and most glass do not qualify. Floors shall be sloped to facilitate the flow of liquid out of the garage. Roll-type garage doors classify use as a garage. *309*
- 8) Double cylinder (interior keyed) deadbolts are not allowed. *311.4.4*
- 9) Chimney terminations must go 3’ above the roof and 2’ above any portion of the building within 10’. *1003.9*
- 10) A 3’ by 3’ landing shall be provided outside of each exterior door. The door leading from the residence to a garage is considered an interior door. A door with two risers (16 ½”) or less to grade is exempt from the landing requirement, other than the required egress door, provided that the door, other than an exterior storm or screen door, does not swing over the landing. *311.4.3*
- 11) Stairs with **four or more risers** require a handrail. Handrail height shall be 30” tall. Handrails must be graspable. Handrails on open side stairs over 30” from grade plane or finished floor shall be guards. Handrails must be on the inside wall of winders Handrail height, measured vertically from the sloped plane adjoining the tread nosing, or finished surface of ramp slope, shall be not less than 30 inches and not more than 38 inches. *311.5.6, S.C amendment*
- 12) Porches, decks, balconies, and ramps over 30” above grade plane require guards. Guards must be a minimum 36" tall unless qualifying as handrails. (34”) Guards cannot allow the passage of a 4” sphere and must resist a 200 lb. lateral load. Elevated screen porches require guards. *312*
- 13) The under floor grade shall have all construction debris removed. Seal all foundation penetrations. *408.4*
- 14) Enclosed accessible areas under stairs, including unfinished basements, must sheetrock inside walls and soffit. *311.2.2*
- 15) All decks, porches, and balconies must be completed and to code. See deck handout. *501.2*

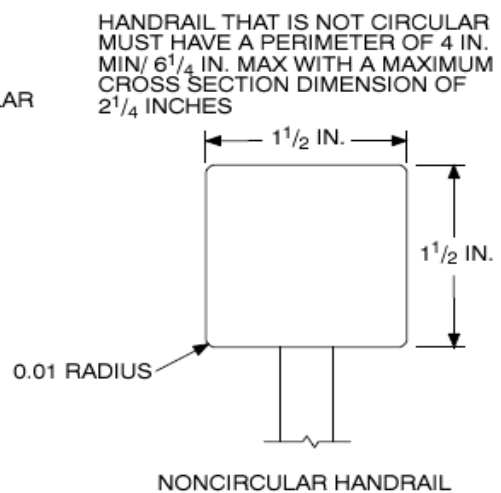
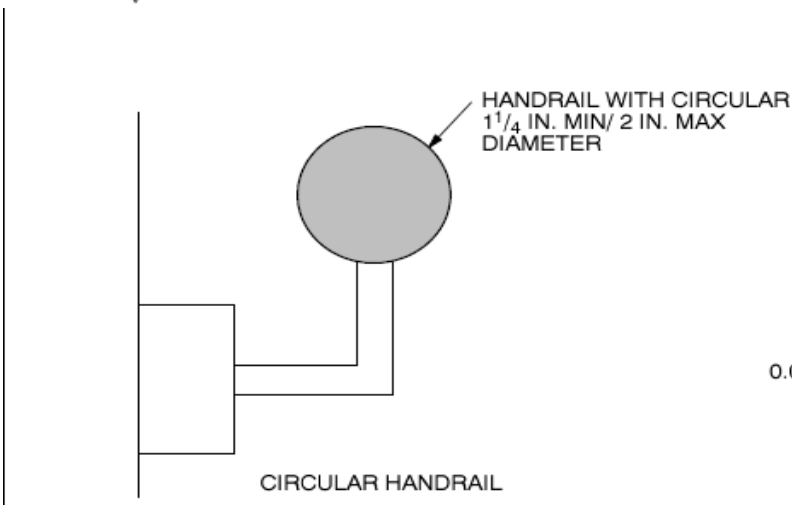
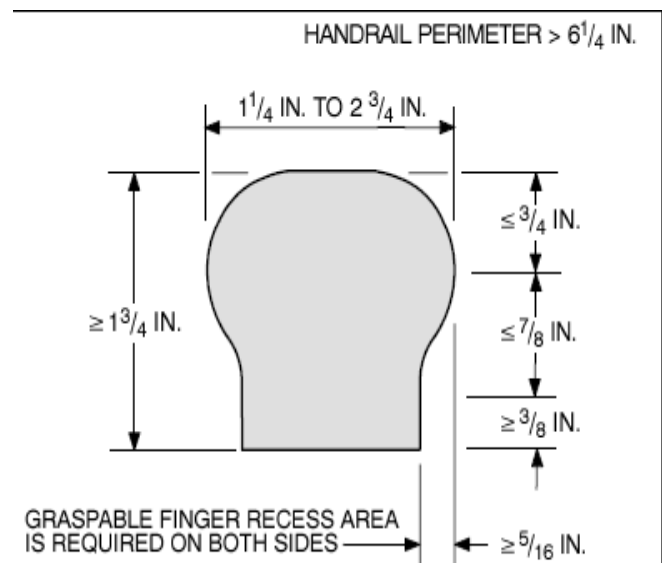
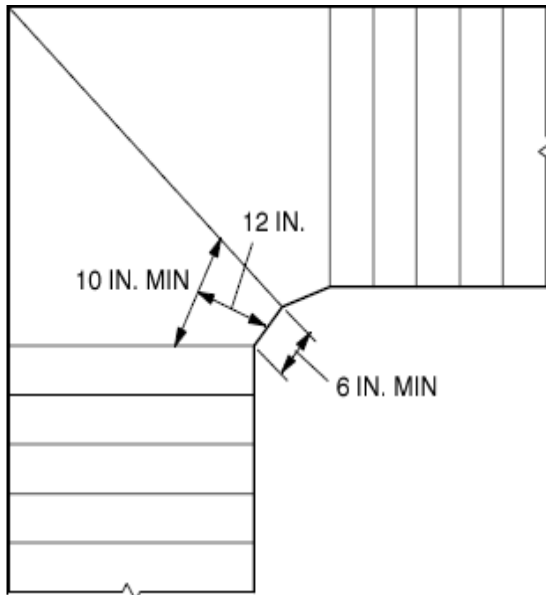
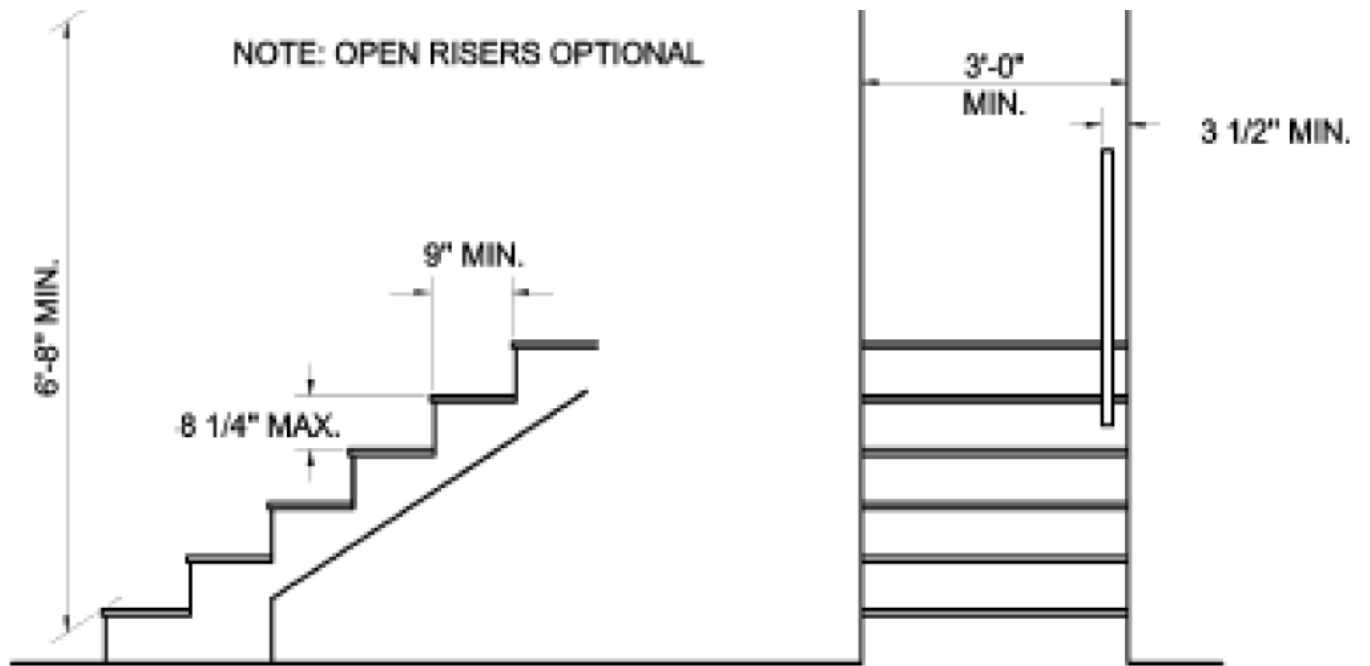

Plumbing Final

- 1) Cut off valve on the cold side to the water heater. *2903*
- 2) The water heater temperature pressure relief valve must safely discharge to the outside of the building. The discharge pipe should be constructed of copper or CPVC. *2803.6.1*
- 3) Water lines in attics, garages, and unconditioned spaces must be insulated against freezing. *2603.6*
- 4) Provide backflow protection in accordance with the code. *2902.2*
- 5) Provide pressure reducing valve and thermal expansion tank per code. *2903.3.1*
- 6) Cleanouts must be accessible. A septic cleanout within 5' of the foundation wall, but not closer than 18" must be provided. *3005.2.7*
- 7) Air admittance valves must be installed per manufacturer's installation instructions. One main stack must run to the exterior. *3114*
- 8) Water heaters located in a garage must be protected from automobile impact. *1307.3.1*

Mechanical Final

- 1) All utilities should be connected, tested, and operational. The exception is gas grills and decorative appliances do not need to be installed at this time. *110.3*
- 2) Gas log fireplaces shall have a shut off valve located outside the firebox but within 6' and in the same room. *2420.5*
- 3) Other than steel pipe, Gas lines should be labeled. The marking shall not be required on piping in the same room with the appliance. *2412.5*
- 4) All gas appliances except grills, lights, dryers, and ranges, require sediment traps.(drip legs) *2419.4*
- 5) Provide lintel to support masonry opening. *606.10*
- 6) Fuel burning appliances shall be provided with make up air. *2407.7*
- 7) Gas appliances located in garage must be elevated a min. 18 "above the floor. *1307.3*
- 8) Appliance installation shall conform to the listing and label of their manufacturer's installation instructions. Instructions shall remain attached to the appliance. *1307.1*
- 9) B-vent clearance min 1" to combustibles. *1306*
- 10) Install pan drain and condensate lines under attic appliance. Remove any loose fill insulation from pan drain. Condensate drain lines shall not be less than 3/4 -inch internal diameter. *1411.3*
- 11) Attics and crawl spaces containing appliances shall be provided with a clear and unobstructed passageway from the access opening to the appliance. *1305.1.3*
- 12) Duct work properly supported and insulated. Duct tape is not allowed. *1601.3.2*
- 13) Recessed can lights in the building envelope shall be properly sealed. *IECC 402.4.3*
- 14) Floor insulation shall be installed to maintain contact with the underside of the sub floor. *IECC 402.2.5*
- 15) Equipment and duct sizing according to ACCA manual J. *1401.3 Oconee County is in climate zone 3 moist b, Indoor Design Temp 72 max heat 75 min for cooling.*
- 16) The building official is authorized to approve above code energy efficiency programs. (LEED, Earth craft, etc.) Such programs require approval at permitting as an alternate method. *IECC 103.1*
- 17) A permanent certificate shall be posted on or in the electrical distribution panel completed by the builder that lists insulation and energy compliance values. *IECC 401.3 see page 12*

Oconee County Building Codes 2006 IECC Energy Code Compliance Certificate

Builder _____	License Number _____
Insulation Co. _____	License Number _____
Heating & Air Co. _____	License Number _____
Permit Number: _____	Date: _____

Envelope Component	Type	Actual Value	Minimum Required
Roof / Ceiling			(R-30>)
Exterior Wall			(R-13)
Attic Knee wall			(R-13)
Floor over unconditioned space			(R-19)
Slab on grade:			(0)
Radiant slab:			(R-5)
Basement (below grade)			(0)
Walkout basement wall			(R-5 mass/R-13 framed)
Unconditioned crawl			(0)
Conditioned crawl			(R-5 mass/R-13 framed)
Ductwork			*(R-6) <i>(R-8 in 2010)</i>
Hot water systems			(R-2)
Windows			*(U.40<) <i>beginning in</i>
Doors			*(U.35) <i>Jan. 1, 2010</i>

Mechanical Summary	Type	Size	Efficiency Standard
Heating System:			(78% AFUE)
Cooling System:			(13 SEER)
Heat Pump:			(7.7 HSPF)
Other Systems:			(e.g. Oil, Geothermal)
Water Heater:			(e.g. Gas/ Elec. BTU)

Certificate shall be readily accessible and posted on the electrical distribution panel and submitted to Building Codes prior to final inspection. List primary type when there is more than one value for each component (i.e. certificate shall list the value covering the largest area). This certificate shall be completed by the builder or registered design professional.

Electrical Final

- 1) Smoke detectors shall be operable per the *IRC* and *NFPA 72 Fire Alarm Standard*. Detectors shall be hardwired interconnected with battery backup located as per code. A monitored security system with integral fire alarm must meet the same standards as a “110” system; battery backup, loudly audible throughout the house, and capable of operation without being monitored. Permit holder is responsible for providing means to activate the detectors, without causing a false alarm, at time of final inspection. *313*
- 2) Warning: Permanent power is contingent upon final inspection approval. *Chapter 1*
- 3) Ground Fault Interrupt Receptacles (GFCI’s) required in all damp locations and the following: bathrooms, garages, kitchen countertops, outdoors, crawl space, unfinished basements, and sinks. *3802*
- 4) All switches and outlets must have covers on. Lighting fixtures must have operable bulbs in them. *3903*
- 5) Circuit board must be legibly marked. Unused openings effectively closed. Properly identify conductors. *3304.5*
- 6) No contamination of electrical equipment. (paint over-spray, insect and bird nests, etc.) *3304.6*
- 7) Circuit breakers sized to match the wire. *3605.1*
- 8) Hydro-massage tub motors and GFCI’s must be accessible. (readily accessible at final inspection) *4109*
- 9) Disconnects for dishwasher, water heater, HVAC, at the unit. *4001.3*
- 10) In use covers required on damp or wet location outlets. *NEC 406.8*
- 11) A receptacle is required on the front and back of each dwelling unit, within 6’6” of grade. *3801.7*
- 12) A switch controlled lighting outlet is required in every habitable room, bath, hallway, stairway with 6 risers, attached garage, storage and appliance attics crawlspaces, basements, and each exterior grade level exit. *3803.1*
- 13) Bathtub and shower spaces cannot have switches, receptacles, pendant fixtures, or ceiling fans. *3902, 3902.11*
- 14) Fixtures in clothes closets must be 24” from the wall or 12” from the shelf. See code for exceptions. *3903.11*
- 15) Arc fault breakers will be required on all bedroom outlet circuits on all homes. However, Arc-fault protection is not required for outlets used solely for smoke and/or fire detection devices. *State modification 3802.1*

Ethics and Administration

The purpose of this checklist is to provide some guidance and act as a reminder of items commonly missed in the past or major changes in the code. It is impossible to develop a complete list of all items without duplicating the codes. It is the responsibility of the permit holder, builder and contractors to insure that the homes they build are in full compliance with the code and all Laws and Ordinances. Oconee County Building Codes will charge a reinspection fee on any items from this checklist not addressed on the first inspection. Other violations noticed and not corrected upon reinspection will be charged a fee only at that time. This is to ensure the efficient allocation of resources involved with the inspection process. This will allow for shorter delays between inspections and hopefully fewer violations being found. Reinspection fees must be paid in the office prior to rescheduling an inspection. Inspectors cannot take money, gifts, or favors. Please do not offer to “buy your lunch” or “let me by this time”. If you do not agree with the inspectors write up, please do not hesitate to appeal the write up to the Building Official. If you feel that the Building Officials decision does not meet the true intent of the code, you can then appeal to the Oconee County Appeals Board. We do appreciate your cooperation and would like to hear from you. A customer satisfaction survey is available at the counter and the staff is always willing to listen to you.

July 1st 2009, the prescriptive energy provisions were replaced by the *2006 International Energy Conservation Code (IECC)*. The following are South Carolina Building Codes Council modifications to the IRC:

2006 INTERNATIONAL RESIDENTIAL CODE

Number	Section	New / Continued
IRC 2006 01	R202	Continued (IRC 2003 01)
IRC 2006 02	Figure R301.2(2)	Continued (IRC 2003 02)
IRC 2006 03	R301, R403, R404, R602, R606, R611, R703 & R1003	Continued (IRC 2003 03)
IRC 2006 04	R301.2.2	Continued (IRC 2003 04)
IRC 2006 05	R305.1(4)	New
IRC 2006 06	R307.2	Continued (IRC 2003 05)
IRC 2006 07	R308.4(5)	New
IRC 2006 08	R311.5.3.1 & R311.5.3.2	Continued (IRC 2003 07)
IRC 2006 09	R311.5.6.1	Continued (IRC 2003 08)
IRC 2006 10	R318	New
IRC 2006 11	R319.1.1	New
IRC 2006 12	R319.3	New
IRC 2006 13	R402.2	Continued (IRC 2003 09)
IRC 2006 14	R403.1.7, R403.1.7.1, R403.1.7.2, R403.1.7.3, R403.1.7.4 & Figure R403.1.7.1	Continued (IRC 2003 12)
IRC 2006 15	R403.1.8	Continued (IRC 2003 13)
IRC 2006 16	R404.1	New
IRC 2006 17	Figure 404.1.5(1)	Continued (IRC 2003 14)
IRC 2006 18	R408.2	New
IRC 2006 19	R408.4 (R408.3 IRC 2003)	Continued (IRC 2003 15)
IRC 2006 20	Table R502.5(1)	Continued (IRC 2003 16)
IRC 2006 21	R502.11.4	Continued (IRC 2003 17)
IRC 2006 22	R602.10.5	New
IRC 2006 23	R602.10.5	Continued (IRC 2003 18)
IRC 2006 24	R613.2	New
IRC 2006 25	R703.7.2, R703.7.2.1 & R703.7.2.2	Continued (IRC 2003 19)
IRC 2006 26	R802.10.1	Continued (IRC 2003 20)
IRC 2006 27	Chapter 11	Continued (IRC 2003 21)
IRC 2006 28	M1411.5 (M1411.4 IRC 2003)	Continued (IRC 2003 22)
IRC 2006 29	M1502.2	New
IRC 2006 30	M1502.6	New
IRC 2006 31	E3801.11 HVAC	New
IRC 2006 32	E3802.12	New